

RETAINER FOR SURFACE MOUNTING OF ANTI-PANIC EMERGENCY AND ACCESS DOORS

AE/V-RPE500

Description

Emergency, panic and access door retainer for surface mounting. Keeps the door closed at rest.



Dimensions

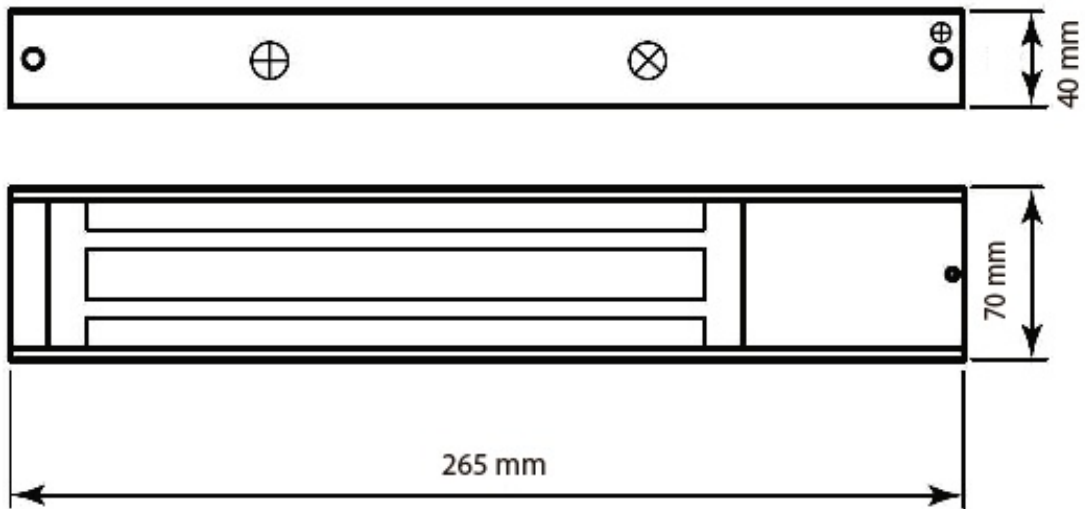

TECHNICAL CHARACTERISTICS

Operating temperature:	-10°C + 55°
Protection degree:	IP40
Power:	24Vdc
Consumption:	250 A
Clamping force:	500Kg / 4900N
Weight:	4.26Kg